

OWNER'S GUIDE | TOTAL GYM® JUMP TRAINER™



total gym®

Congratulations

Thank you for choosing Total Gym® products and services. Total Gym functional incline training equipment has set the standard for physical rehabilitation, athletic training and sports performance since 1974.

As with all of our products, we trust that your Total Gym Jump Trainer™ will provide you with unsurpassed service and versatility year after year in the clinical and/or commercial setting.

The most innovative design for lower body strengthening, the Jump Trainer uniquely provides a dedicated machine for plyometric training as well as a plethora of other lower body exercises.

Your Total Gym product arrives with assembly required. Simply follow the directions for assembly and set-up your Jump Trainer to be operational.

In this Owner's Guide, you will find information about your Total Gym Jump Trainer and its component parts, operation, maintenance and care. Additionally, you will find usage and safety tips, as well as safety precautions and warranty information. Please save this guide and refer to it in the future. You can also download a copy from our website for your convenience at www.totalgym.com/jumptrainer.

We value you as a customer and your feedback is important to us. If you have any questions or need further information about your Total Gym Jump Trainer, please contact our customer experience department at (858) 586-6080 or email support@totalgym.com.

Yours in health,

A handwritten signature in black ink, appearing to read 'Jesse Campanaro', with a long horizontal flourish extending to the right.

Jesse Campanaro
CEO

Table of Contents

Safety Precautions	4	Slide Distance Regulator (SDR) Instructions	13
Parts Identifier	5	Variable Resistance Band Instructions	13
Specifications and Limitations	6	Resistance Charts	13
Assembly Instructions	7-11	Maintenance and Care	14
Getting Started	12	Maintenance Schedule	14
Exercise Instructions	12	Glideboard: Roller Removal and Assembly	14
		Warranty Information.....	15
		USA Warranty	15
		Limited Warranty	15
		Warranty Claims	15

Safety Precautions

Before starting this or any exercise program, consult your physician, who can assist in planning a program that is age and ability specific. Certain exercise programs or types of equipment may not be appropriate for all people. Ensure that your clients are able to participate in an exercise program on this equipment.

- Do not overexert, or allow your clients to overexert using this equipment or performing any exercise program on this equipment. If any pain or tightness in the chest occurs, an irregular heartbeat, shortness of breath, faintness, nausea or dizziness is experienced by you or your client stop the exercise session immediately and ensure that a physician is consulted before resuming any exercise program. (Clinicians and trainers should follow these recommendations if these symptoms are observed in clients.)
- This product is designed and intended for commercial use. Clinicians and trainers should inform clients of and monitor their adherence to all safety precautions. Use only as directed.
- Do not permit anyone to stand on the Total Gym Jump Trainer glideboard or use it as furniture. Children should only use the Jump Trainer when closely attended and supervised by an adult. Do not leave children or clinical patients unattended on Total Gym equipment.
- Parents and others in charge of children should responsibly monitor children whose natural play instinct and fondness of experimenting can lead to situations and behavior for which the training equipment is not intended.
- If children are allowed to use the equipment, their mental and physical development and above all their temperament should be taken into account. They should be controlled and instructed in the correct use of the equipment.
- The equipment is under no circumstances suitable as a children's toy.
- Keep fingers, loose clothing and hair away from moving parts. Wear appropriate exercise attire and tie long hair back.
- Inspect your Total Gym Jump Trainer before each use to ensure proper operation. Check all parts for wear before each use. Do not use your Total Gym Jump Trainer if it is not completely assembled or if it has been damaged in any manner. Contact Total Gym Customer Experience Department at (858) 586-6080 for replacement parts or repairs.

- Follow instructions in this Owner's Guide for using the unit. Improper use could result in severe or fatal injury. Your Total Gym Jump Trainer must be bolted to the floor on a flat, solid surface with nonskid material underneath. Keep the area around it free from obstructions. The Total Gym Jump Trainer is rated at a maximum user weight capacity of 400 lbs. [180 kg.].

⚠ WARNING

READ ALL INSTRUCTIONS BEFORE USING TOTAL GYM JUMP TRAINER.

1. Inspect your Total Gym Jump Trainer unit before each use to ensure proper operation. Do not use this equipment unless all moving parts are working properly. Follow all maintenance and care instructions found in this Owner's Guide and on the equipment labels.
2. Close supervision is necessary when the Total Gym Jump Trainer is used by or near children, disabled or injured persons.
3. Care should be taken at all times when getting on and off your Total Gym Jump Trainer or any exercise equipment. Falling on or off the product could result in injury, or possibly death. Follow the "Getting Started" instructions for using the unit found in this Owner's Guide.
4. Use your Total Gym Jump Trainer only for its intended purpose.
5. Use correct biomechanical positioning during exercise and hold handles whenever possible.
6. Keep fingers, loose clothing and hair away from all moving parts.
7. Parts of the Total Gym Jump Trainer are made with natural latex that has been known to cause allergies in certain people.
8. Usage Class: Class S per ISO 20957
Compliant to the General Product Safety
Directive 2001/95/EC.



The Total Gym Jump Trainer has been tested to comply with CE and other safety standards.

Parts Identifier



Specifications & Limitations

- Glideboard Range of Motion: 38 inches [97 cm]
- Weight Capacity: Maximum user weight capacity of 400 lbs [180 kg]
- Unit Weight: 230 lbs [105 kg]

- Floor Space: 24 square feet [2.2 square meters]
- Must be bolted to the floor
- Clearance: Keep side areas clear 0.6 m or more.

PHYSICAL THERAPY SETTING

102" [2.6 m] x 33" [.8 m] x 62" [1.6 m] (L/W/H)

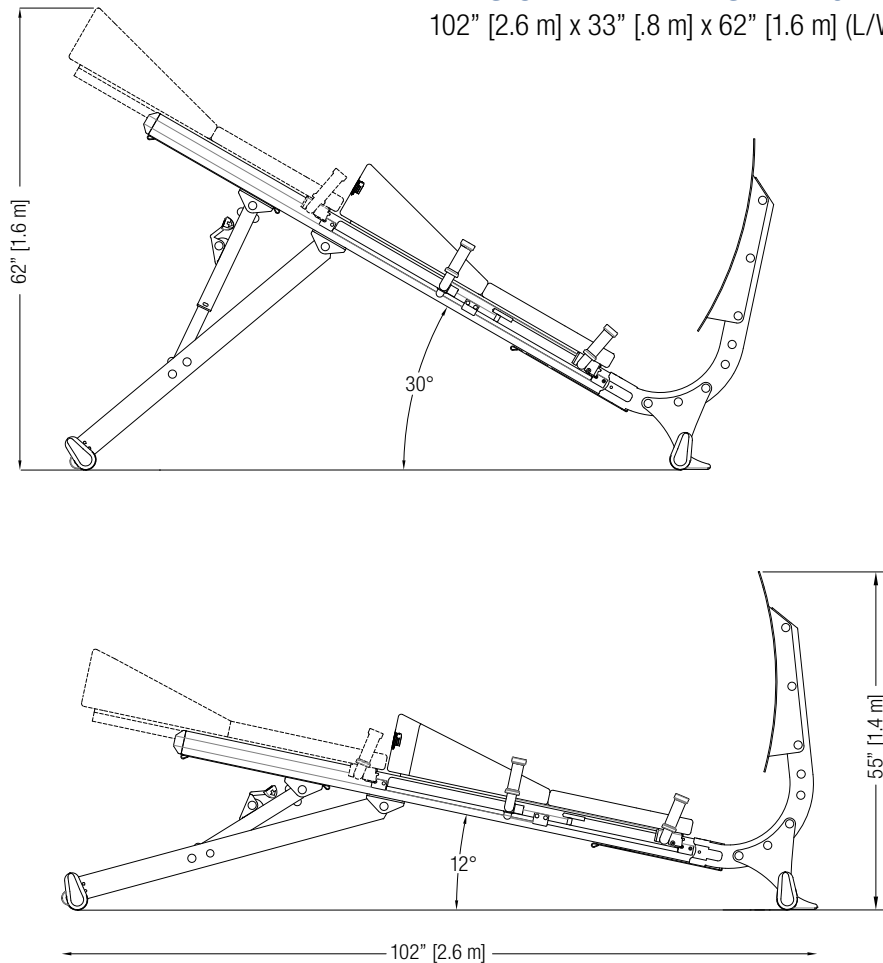

FITNESS SETTING

104" [2.6 m] x 33" [.8 m] x 68" [1.7 m] (L/W/H)

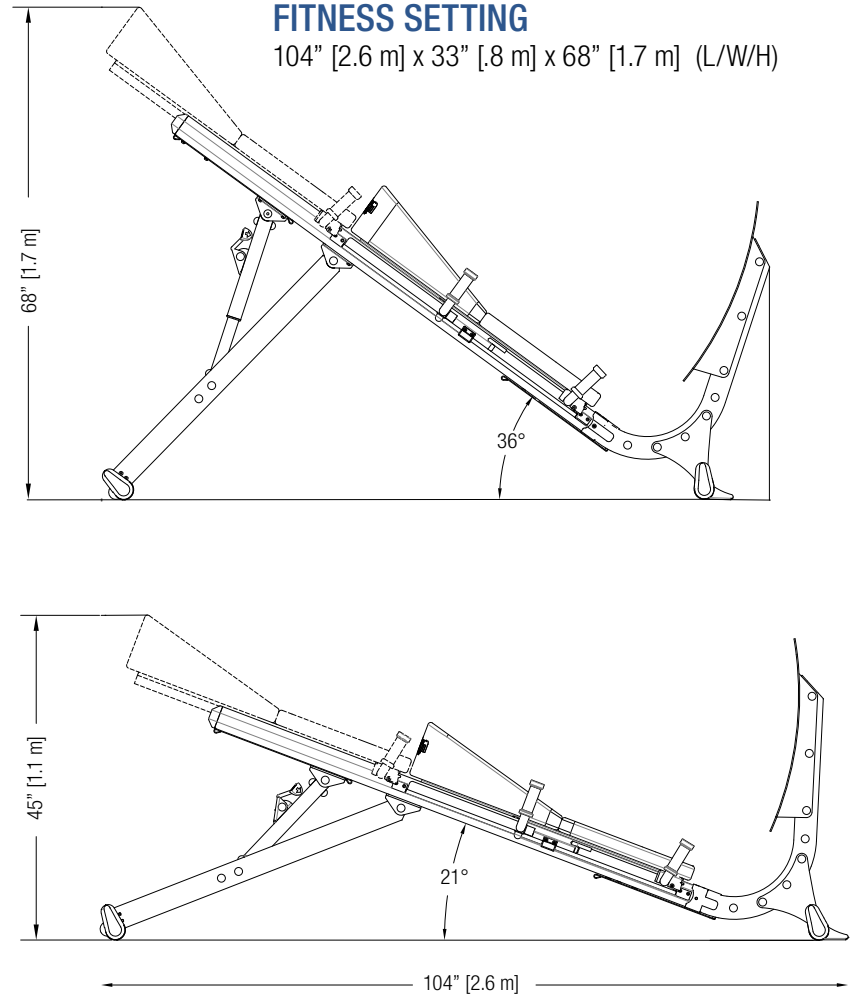

Assembly & Installation

TWO PERSON ASSEMBLY REQUIRED.

NOTE: THERE ARE TWO INSTALLATION SETTINGS: PHYSICAL THERAPY AND FITNESS. PLEASE BE SURE TO ASSEMBLE YOUR JUMP TRAINER PER YOUR NEEDS IN ACCORDANCE WITH THESE DIRECTIONS.

STEP 1. Carefully unpack all the parts and the hardware kit for your Total Gym Jump Trainer and inspect to see if anything is missing or damaged. Contact Total Gym Customer Experience Department immediately if you do not find all items shown below:

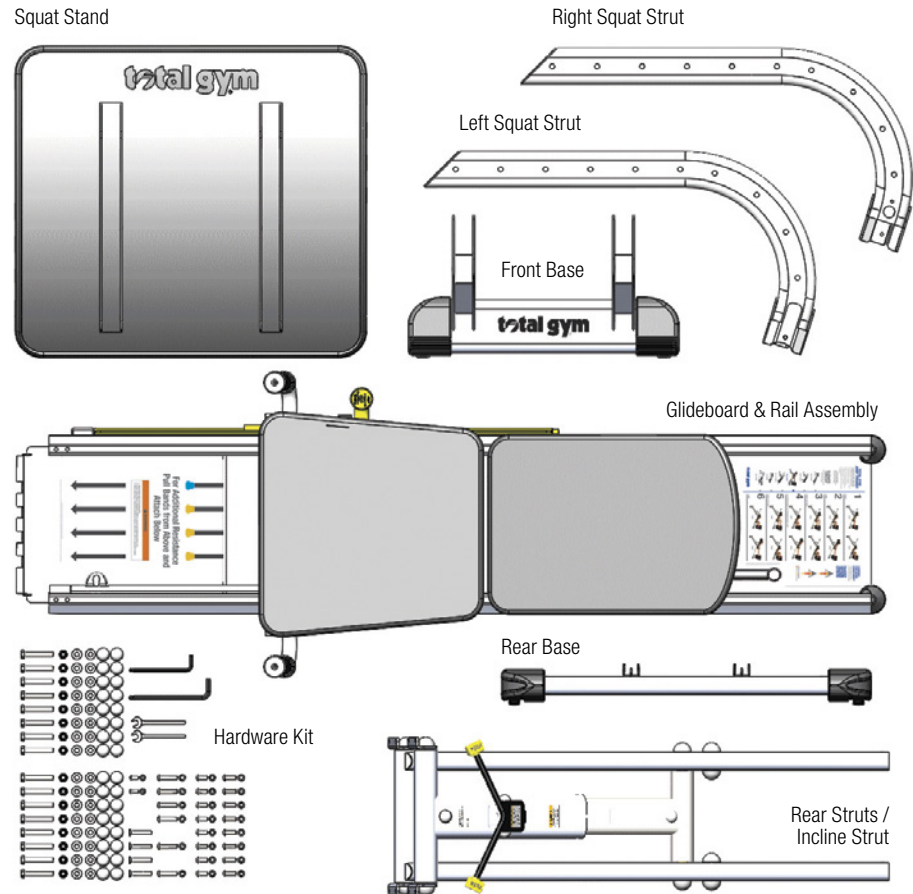

HARDWARE KIT included comes pre-grouped by assembly steps.

NOTE: Letters designate each type of hardware to be used throughout these instructions. Consult this page for reference.

STEPS 2 & 3

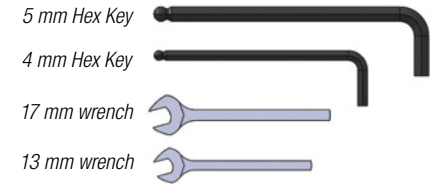
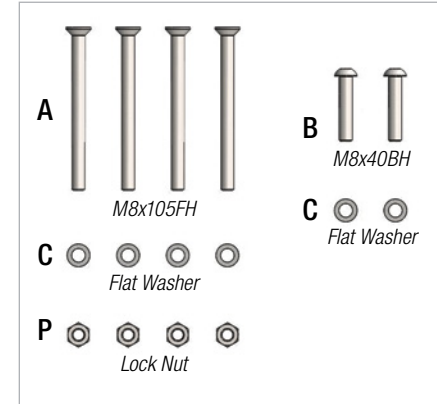

STEP 8

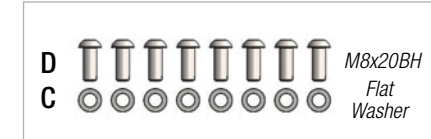

STEP 4

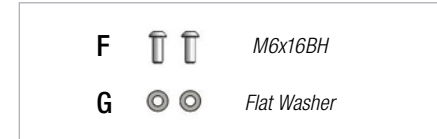

STEP 9



STEP 5, 6 & 7

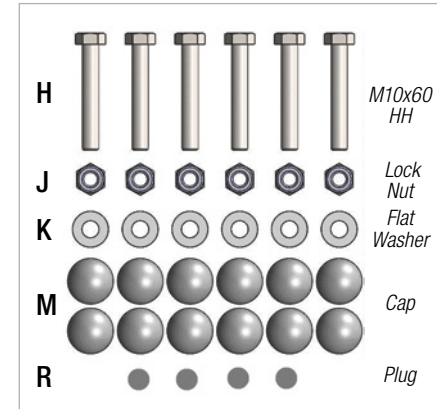

STEP 10

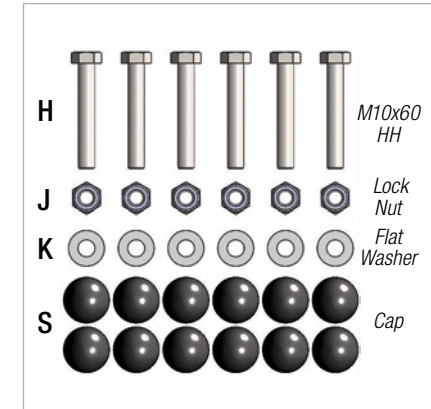

STEP 2. Insert the Left Squat Strut on to the Left Rail by positioning the bottom of the Left Squat Strut in-between the Left Rail and Bungee Panel (as shown in close-up below). Gently wiggle the Strut all the way on to the Rail until the holes are aligned. Install the hardware (A, B, C, P) as shown. Do not tighten completely.

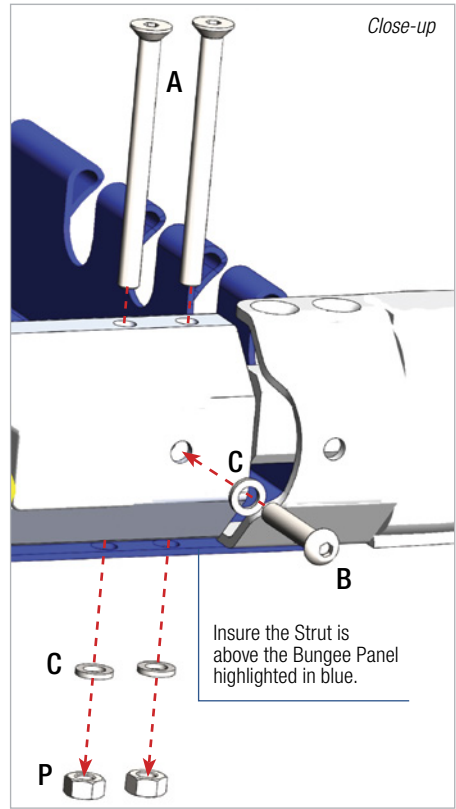
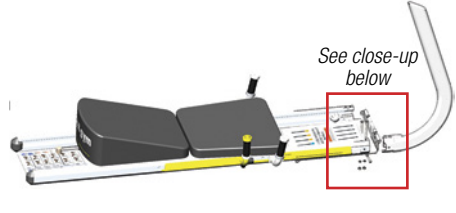

STEP 3. Repeat STEP 2 on other side, attaching the Right Squat Strut to the Right Rail using the hardware (A, B, C, P) as shown, but do not tighten completely.

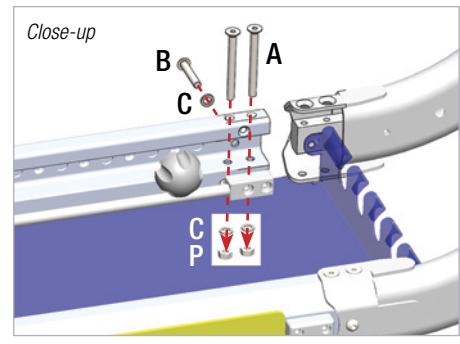
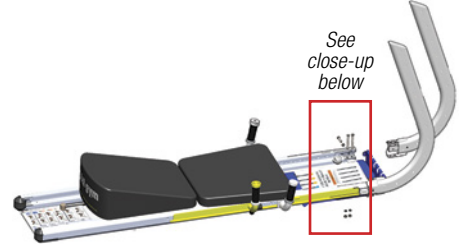

STEP 4. Install the hardware (G, F) on both rails as shown below.

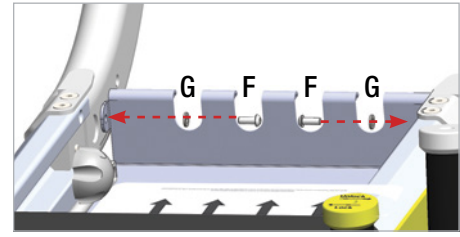

DECIDE WHICH INSTALLATION SETTING IS APPROPRIATE FOR YOU: PHYSICAL THERAPY OR FITNESS.

PHYSICAL THERAPY ASSEMBLY

STEP 5. PHYSICAL THERAPY ASSEMBLY FOR FITNESS ASSEMBLY SKIP TO STEP 6. Using hardware (R), as indicated, first insert plastic plugs into hole 4 on the inside and outside of each Strut (as shown below).

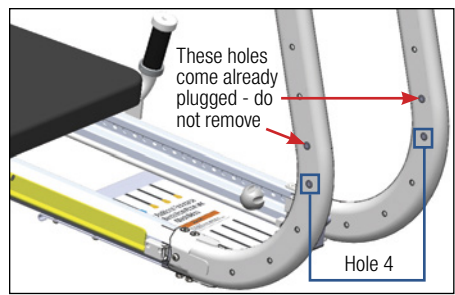

Next, attach Front Base to holes 1, 2 and 3 as shown below using hardware (H,K,J) as indicated. Make sure to install the washer (K) on the bolt first (H). After all the bolts and nuts are installed, tighten them completely. Then cover each with a plastic cap (M).

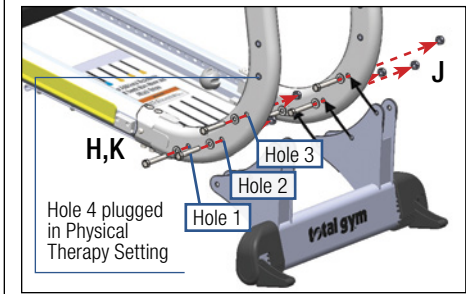

This is how the Front Base attached to the Struts should look for the PHYSICAL THERAPY Setting.

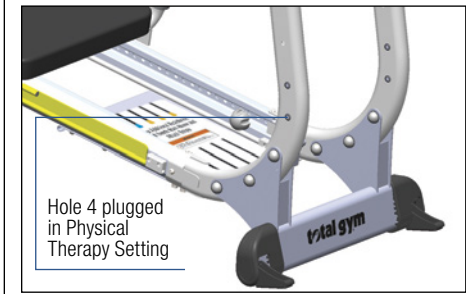

TO CONTINUE PHYSICAL THERAPY ASSEMBLY SKIP TO STEP 8.

FITNESS ASSEMBLY

STEP 6. FITNESS ASSEMBLY FOR PHYSICAL THERAPY ASSEMBLY GO BACK TO STEP 5

Using hardware (R), as indicated, first insert plastic plugs into hole 1 on the inside and outside of each Strut (as shown below).

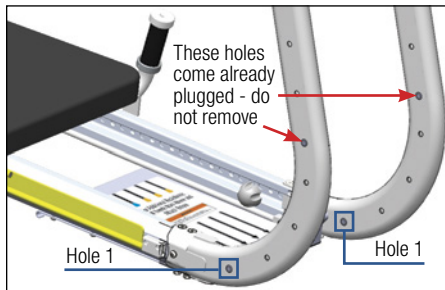

Next, attach Front Base to holes 2, 3 and 4 as shown below using hardware (H,K,J) as indicated. Make sure to install the washer (K) on the bolt first (H). After all the bolts and nuts are installed, tighten them completely. Then cover each with a plastic cap (M).

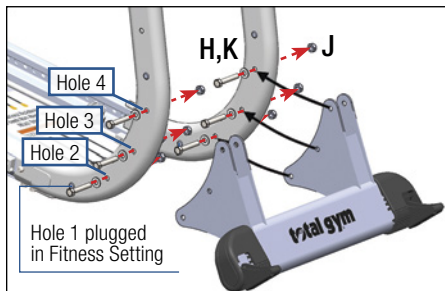

The image below is how the Front Base attached to the Struts should look for the FITNESS Setting.



STEP 7. FITNESS ASSEMBLY FOR PHYSICAL THERAPY SETTING SKIP TO STEP 8

Adjust Rear Struts / Incline Strut for FITNESS Setting.

NOTE: The Rear Strut / Incline Strut comes factory assembled in the PHYSICAL THERAPY Setting. Only do this step if you want your Jump Trainer assembled for the FITNESS Setting.

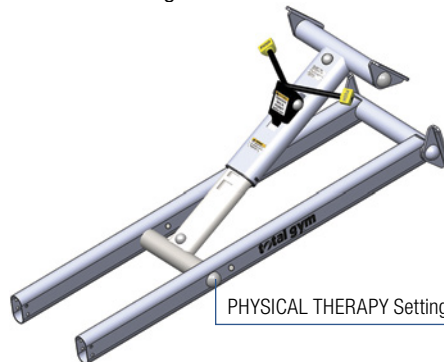

7A. Remove the two caps and four plugs. Remove a nut from the axle with the two wrenches. Pull axle out completely.

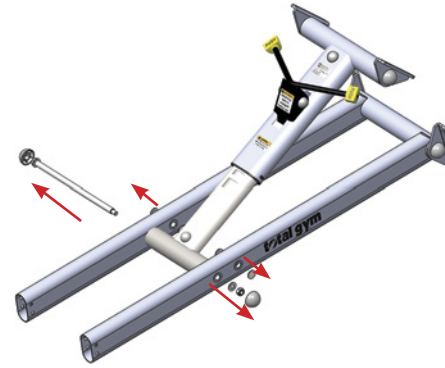

7B. Gently push out struts to prevent scratching paint as you slide Incline Strut up to the FITNESS hole.

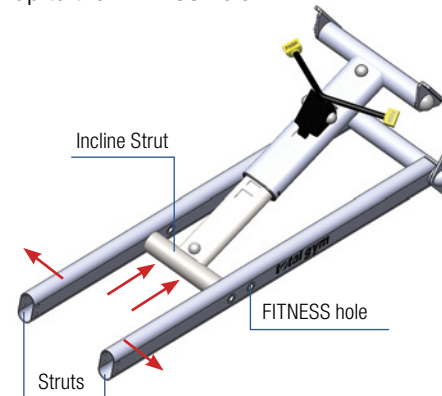

7C. Reinstall the axle and nut with the two wrenches and tighten completely; then press on the two caps and four plugs.

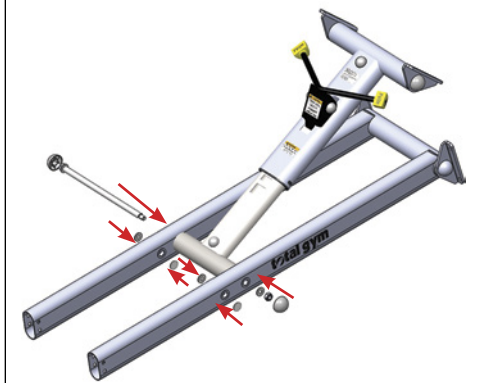

The Incline Strut is now installed on Rear Struts for FITNESS Setting.



TOTAL GYM® JUMP TRAINER™ OWNER'S GUIDE | ASSEMBLY & INSTALLATION

STEP 8. Using the hardware (D, C) as indicated; attach the Rear Base to the Rear Struts as shown below. Ensure both the Total Gym logo and the warning stickers are right side up. Install screws 1 and 2 first, then proceed to install the rest; tighten completely.

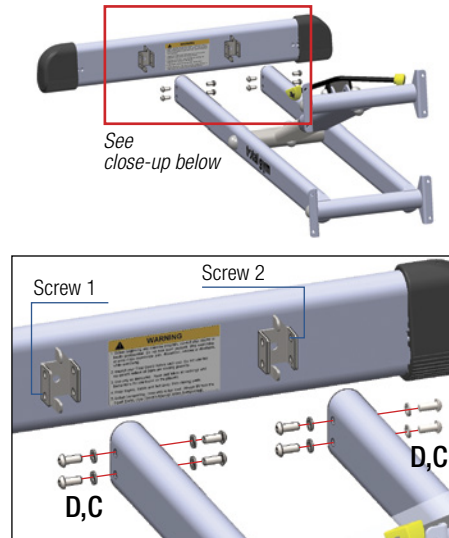

STEP 9. Lay the Jump Trainer on its side. Using the hardware (C, E) as indicated; attach the Rear Struts / Incline Strut as shown. Tighten completely.

NOTE: Installing the screws in the order shown may be easiest.

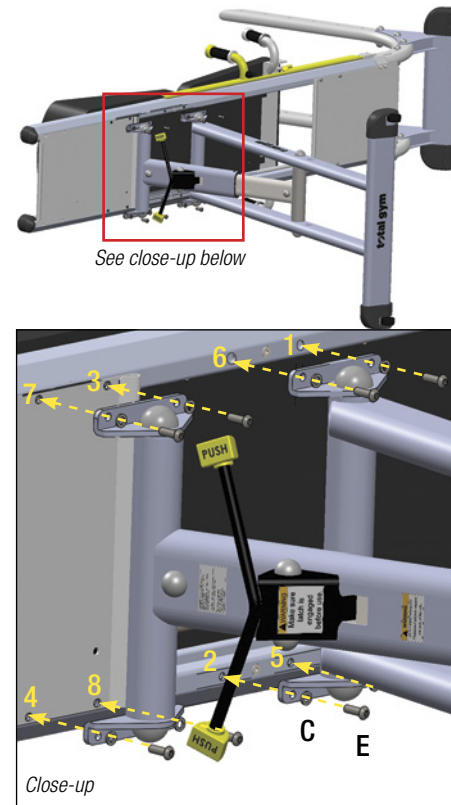

STEP 10. Turn the Jump Trainer upright and, using the hardware (H, J, K, S) as indicated; attach the Squat Stand to the Struts. Tighten completely. Installing the screws in the order shown may be easiest. Once screws are fully tightened, push on all 12 caps (S).

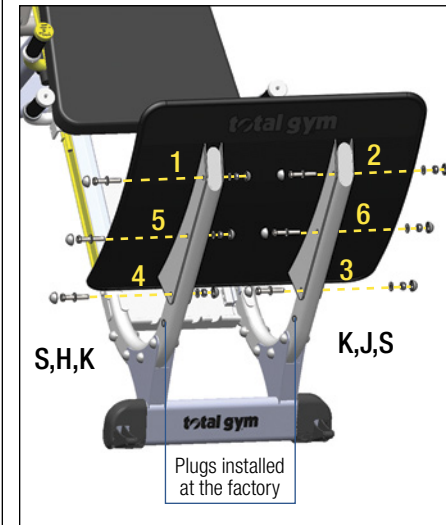

STEP 11. IMPORTANT: RETURN TO STEPS 2-4 AND TIGHTEN ALL SCREWS COMPLETELY.

STEP 12. The screws A in step 2 and 3 may become loose after use in one day due to stretching and seating of other parts. Retighten those screws and nuts P if they become loose. One retightening is usually enough.

STEP 13. Move the Jump Trainer to the permanent location and position it properly for full function.

To ensure you have positioned the Jump Trainer with enough clearance before bolting to the floor, first lower the Incline Strut to the lowest level. From the Floor Anchor Bolt Holes measure at least 104 inches [3.56 m] from the Bolt Holes behind the machine to any walkway, or at least 140 inches [3.56 m] away from any wall or obstruction.

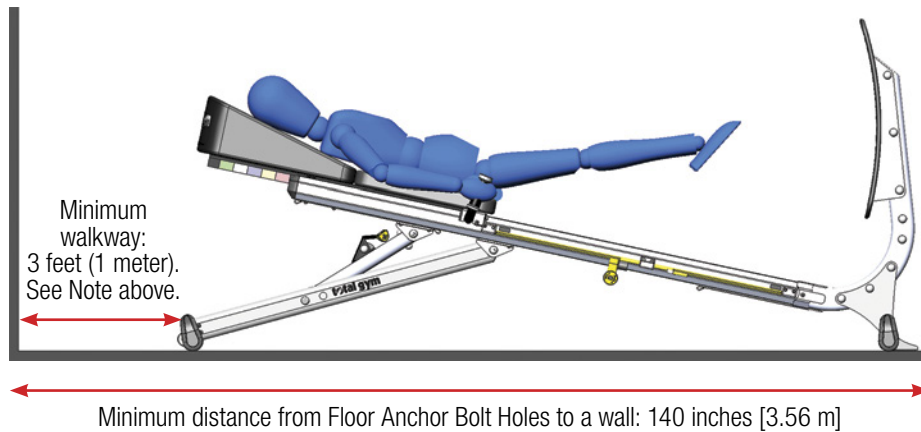

Bolt down machine at Front Base through the Bolt Holes provided on the Anchor Feet. **NOTE: INSTALLATION MUST BE CARRIED OUT BY A PROFESSIONAL INSTALLER.**

This will warrant enough room for full range of motion of the Glideboard at the rear of the unit.

NOTE: There should also be at least 3 feet (1 meter) distance between the Rear Base and a wall or walkway. Consult your local government guidelines.

STEP 14. Anchor the Front Base to the floor using appropriate bolts for your floor as shown below.

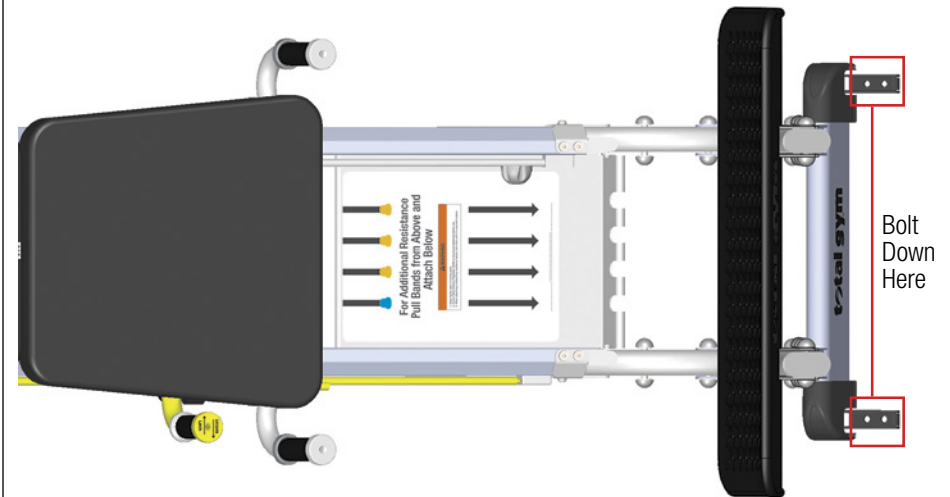

⚠ WARNING!

1. MACHINE WILL MOVE IN-USE IF NOT BOLTED TO THE FLOOR
2. Bolt unit 104 inches [2.64 m] from the Bolt Holes to any walkway behind the machine or at least 140 inches [3.56 m] from any wall or obstruction.

Getting Started

As a facility offering the use of the Total Gym Jump Trainer to customers, or as a personal user of the product, you – the owner of the product – assumes the responsibility to become familiar with the guidelines relative to safe use of the product and to convey these guidelines to all users. Read all safety, warnings and usage instructions before using the Total Gym Jump Trainer. Care and maintenance for this product are included to promote safe, enjoyable use of this equipment.

When using your Total Gym Jump Trainer, wear athletic shoes and comfortable lightweight clothing. Before you begin, check to ensure that all parts are in place and working properly. Check that the Safety Lock is engaged and that the Jump Trainer is set to the appropriate incline level and/or variable band resistance for your or your client's ability. Begin your exercise program with the basic moves provided. As your proficiency increases, adjust the resistance, incline or movements to increase the intensity. Remember to control the glideboard at all times, particularly when getting on or off your Total Gym Jump Trainer. Always engage the Safety Lock before exiting.

WARNING!

Always control the glideboard while mounting, dismounting or lifting your Total Gym Jump Trainer. Total Gym Jump Trainer is rated at a maximum user weight capacity of 400 lbs [180 kg].

Stay clear of back of unit as glideboard extends beyond rails.

Exercise Instructions

Follow the instructions on the placard as illustrated below by doing the desired number of sets and repetitions appropriate for the skill and level of difficulty.

Before entering unit, inspect glideboard to ensure safety lock is engaged.

SQUAT JUMP

1. Lay back on glideboard with feet on platform
2. Disengage safety lock
3. Grasp handles
4. Bend knees
5. Jump

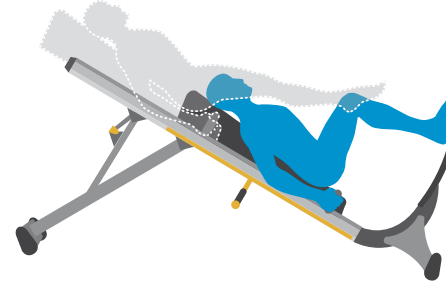

Scan for more exercises or visit www.totalgym.com/jumptrainerexercises

Select appropriate resistance level.

INCREASE RESISTANCE

To increase resistance, raise rails to desired level.

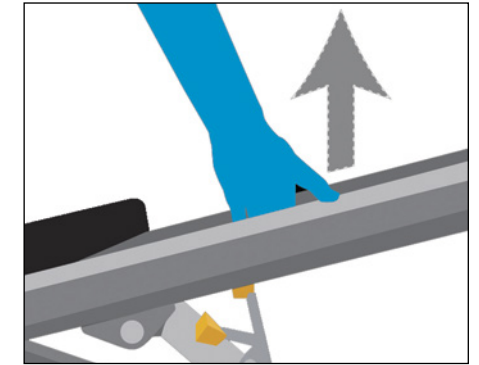

DECREASE RESISTANCE

To decrease resistance, lower rails to desired level.

1. Lift rails slightly
2. Push lever down
3. Lower to desired level

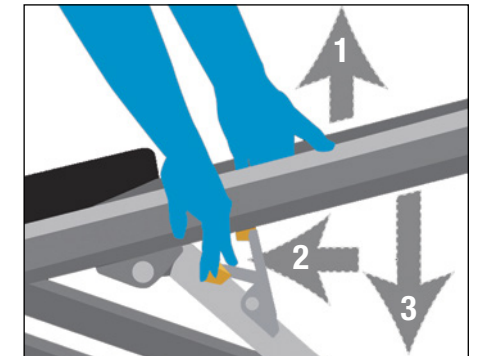

Slide Distance Regulator (SDR) Instructions

The function of the Slide Distance Regulator (SDR) is to reduce the motion of the glideboard in the downward direction to prevent excessive knee flexion in rehabilitation exercises. To set the SDR to a desired position, disengage safety lock and move the glideboard up about one inch above the lowest position you want the glideboard to go. Hold that position while you unscrew the SDR knob and pull it out. While holding the knob out, slide it toward the glideboard as close as it can go. Release the knob and slide it down the Right Rail until it is engaged in one of 12 positions. Then tighten the SDR knob and begin exercising.

Variable Resistance Band Instructions

For additional resistance you can add variable band resistance using the four bands located beneath the bottom of the glideboard. To attach bands, pull the knobs down and hook them to the rack. Do not do this while on the machine. Detach bands after each use to preserve life.

For replacement bands call 858-586-6080.

Resistance Charts

JUMP RESISTANCE CHART – FITNESS SETTING

Nominal % of Bodyweight	Level	Squat Resistance % of Your Body Weight (lbs/kgs)						
		100/45	130/59	150/68	180/82	200/91	300/136	400/181
80	7	87	81	78	75	73	69	66
75	6	82	76	73	70	69	64	62
70	5	76	71	68	65	64	60	58
65	4	71	65	63	60	59	55	53
60	3	65	60	58	55	54	51	49
55	2	59	54	52	50	49	46	44
50	1	52	48	47	45	44	41	40

Bungees add resistance in 10 lb increments from 10 to 70 lbs

JUMP RESISTANCE CHART – PHYSICAL THERAPY SETTING

Nominal % of Bodyweight	Level	Squat Resistance % of Your Body Weight (lbs/kgs)						
		100/45	130/59	150/68	180/82	200/91	300/136	400/181
65	7	74	68	66	63	62	58	56
60	6	67	62	60	58	56	53	51
55	5	60	56	54	52	50	47	46
50	4	53	49	47	45	44	42	40
45	3	46	42	41	39	38	36	35
35	2	38	35	34	33	32	30	29
30	1	31	28	27	26	26	24	23

Bungees add resistance in 10 lb increments from 10 to 70 lbs

Maintenance and Care

Your Total Gym Jump Trainer unit will offer you or your facility and your clientele years of easy operation if you follow these simple tips for maintenance and care. With periodic cleaning, moving parts and rolling surfaces will maintain their smooth function. The Total Gym Row Trainer is not safe to use if it is not maintained regularly as follows. Clean rail surfaces on a regular basis with a noncorrosive cleaner like soap and water or waterless cleaner or just wipe clean with a dry towel. Some black powder residue is normal on the inside of the rails. All other parts can be cleaned the same way or antibacterial wipes may be used. If your Total Gym Row Trainer is damaged, please discontinue use until defective components are repaired. Please pay special attention to the following wear items: rollers, bungees, brake strut and handle grips.

Caution! DO NOT USE ANY LUBRICANTS OR SILICONE-BASED PRODUCTS on the rails or wheels. This will cause the wheels to slide rather than roll and will damage the wheels. You can clean the glideboard material with a non oil-based window cleaner. DO NOT USE ARMOR ALL® OR LIKE SUBSTANCES. These will make the glideboard slippery. Wipe down your Total Gym Jump Trainer with a clean cloth.

MAINTENANCE SCHEDULE

DAILY

1. Wipe down all padded surfaces with antibacterial cleanser after each use.
2. Move the glideboard up and down rails to ensure smooth rolling. If glideboard does not roll smoothly, clean rails and wheels thoroughly.

WEEKLY

1. Wipe down rails with a non-corrosive, no alkaline, no alcohol cleanser.
2. Clean all surface areas for aesthetics.
3. Check all screws, fastener to ensure they are installed correctly and tightened.
4. Check all pads, fabric or foam for punctures or wear and replace as needed.

MONTHLY

1. Visually inspect the rollers. Clean any debris accumulated on the roller.
2. Inspect rubber stoppers.
3. Inspect resistance bands for deterioration or tears.
4. Replace all parts that show signs of wear. Contact the Customer Experience Department in the USA at 1-800-541-4900 or support@totalgym.com. For All other countries, contact the approved distributor in your country.

Glideboard: Roller Removal and Assembly

STEP 1. Remove the six M6 screws from both the Rail End Caps on the top end of the rails with a 4 mm Hex Wrench (not included) and remove the end caps.

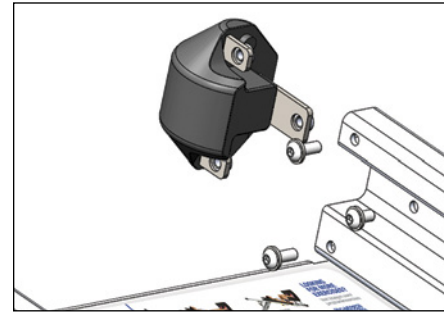

STEP 2. Remove the gas strut brake by unscrewing two screws below the top placard panel with a 5mm Hex wrench (Not included).

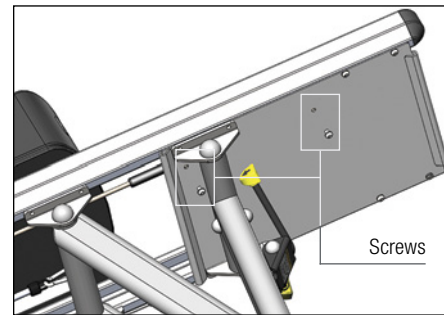

STEP 3. Roll the glideboard up and out the top of the rails and set it upside down on a clean smooth surface.

STEP 4. To remove the rollers use a 13 mm socket wrench and a 13 mm open-end wrench. Insert socket wrench over the bolt on the outside of the roller as you engage the open-end wrench on the nut on the inside of the frame; turn to unscrew.

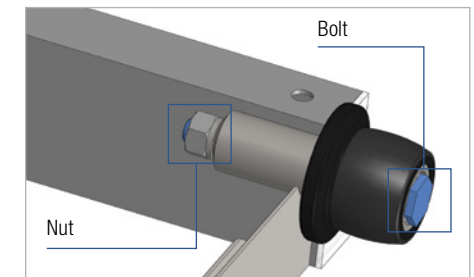

NOTE: Socket wrench and open-end wrench not included.

STEP 5. Replace the rollers as needed and reinstall the bolt and nut. Tighten just enough so that the wheel can roll but does not slide lengthwise on the axle. **DO NOT OVER TIGHTEN.**

STEP 6. To reinstall the glideboard by carefully & slowly rolling it into the rails.

STEP 7. Replace the gas strut brake and insure both screws are tight.

STEP 8. Replace the rail end caps on the rails and insure all 6 screws are tight.

Warranty Information

US WARRANTY

Warranties outside the US may vary. Contact your local authorized distributor for details.

TOTAL GYM JUMP TRAINER™

Commercial Warranty:

- Frame – 5 years
- Parts & Upholstery – 1 year
- Foam, Rubber & Bands – 90 days

LIMITED WARRANTY

Improper use of Total Gym Jump Trainer: Defects or damage that result from improper use are excluded from coverage.

WARRANTY CLAIMS

Total Gym® treats warranty claims as a priority. To process these quickly, a Return Merchandise Authorization (RMA) number is required to properly link your merchandise with your claim. Total Gym does not accept returned merchandise without an accompanying RMA number. Contact Total Gym Customer Experience Department at 1-800-541-4900 if you are making a warranty claim. A representative will issue you an RMA number and instructions for proper packaging of the equipment for shipping.

IMPORTANT: Save your invoice. Please retain packaging instructions. US Customer Service Center: 858-586-6080. Shipping Damage: FOB origin, unless otherwise specified.

Total Gym accepts no responsibility for damage in shipping. Total Gym does, however, make every effort to facilitate the satisfactory resolution of claims made against delivery agents for damage during shipping. If the package appears to have sustained damage in shipping, or if your Total Gym Jump Trainer appears to have shifted in delivery but no damage is evident, retain the shipping boxes until the Total Gym has been fully assembled to ensure there is no functional damage that is not initially visible. In the event of damage during shipping, retaining the shipping boxes helps to facilitate your claim against the shipper. Take photographs of damaged boxes or contents before opening.

PURCHASE RECORD Retain this copy for your records.

Date Purchased _____

Purchased From _____

Model Name: Total Gym Jump Trainer, Part # 5900-01

Serial Number _____

TotalGym.com

Customer Service:
858.586.6080

7755 Arjons Drive
San Diego, CA 92126

TotalGym.com

Customer Service: (858) 586-6080

7755 Arjons Drive, San Diego, CA 92126